

STANDARD SPECIFICATION

MATERIAL: GALVANNEAL

GAUGE: 18

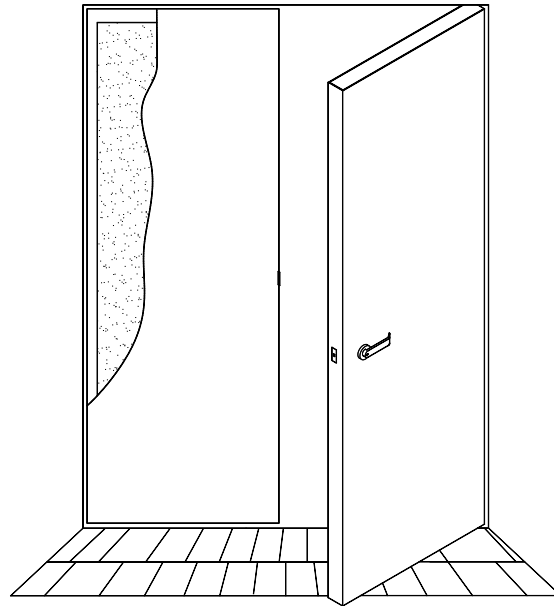
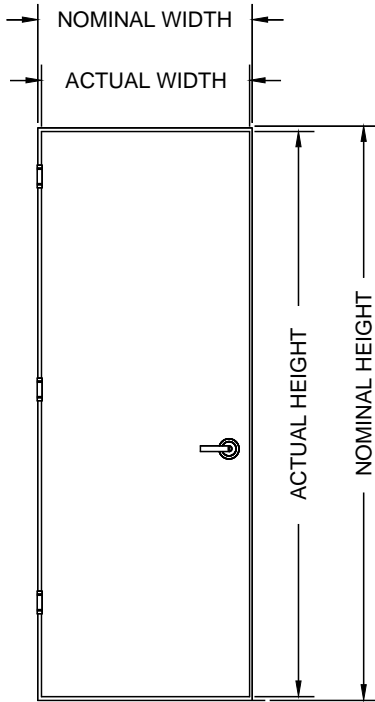

- 1.) 1-3/4" STANDARD DOOR THICKNESS, OTHER THICKNESSES AVAILABLE.
- 2.) 16, 14 AND 12 GAUGE AVAILABLE.
- 3.) G90 GALVANIZED AVAILABLE. STAINLESS STEELS 304 AND 316 AVAILABLE IN #4-SATIN, #2B-MILL OR #8-MIRROR FINISHES.
- 4.) 2 LB DENSITY POLYURETHANE CORE PERMANENTLY BONDED TO BOTH FACE SHEETS.
- 5.) THERMAL BARRIER R-FACTOR: 2.77 TESTED PER SDI-113, ASTM C1199/E1423
- 6.) 18 GA TOP AND BOTTOM CHANNELS SPOTWELDED TO FACE SHEETS.
- 7.) CONTINUOUS WELD SEAMLESS EDGE (STANDARD FOR MILD STEEL - OPEN SEAM AVAILABLE).
OPEN SEAM EDGE (STANDARD FOR STAINLESS STEEL - SEAMLESS AVAILABLE).
- 8.) HARDWARE REINFORCEMENTS:
3/16" FOR HINGES
12 GA FOR LOCKS
14 GA FOR CLOSER

