

**HOLLOW  
METAL  
MANUAL**

**NAAMM  
STANDARD**

**HMMA 820-08**

METAL FRAMES



NAAMM HMMA 820-08

# HOLLOW METAL FRAMES

NAAMM HMMA 820-08



METAL FRAMES



This manual was developed by representative members of the Hollow Metal Manufacturers Association Division (HMMA) of the National Association of Architectural Metal Manufacturers (NAAMM) to provide information and guidance on the installation and storage of hollow metal doors and frames. This manual contains advisory information only and is published as a public service by NAAMM and its HMMA Division.

**NAAMM AND ITS HMMA DIVISION DISCLAIM ALL LIABILITY OF ANY KIND FOR THE USE, APPLICATION OR ADAPTATION OF MATERIAL PUBLISHED IN THIS STANDARD.**

*Purchasers of NAAMM Standards may receive current information on all NAAMM Standards by calling or writing the National Association of Architectural Metal Manufacturers, or by visiting our website at [www.hollowmetal.org](http://www.hollowmetal.org).*

**National Association of Architectural Metal Manufacturers**

800 Roosevelt Road

Bldg. C, Suite 312

Glen Ellyn, Illinois 60137

Phone: (630) 942-6591 Fax: (630) 790-3095

[www.naamm.org](http://www.naamm.org)

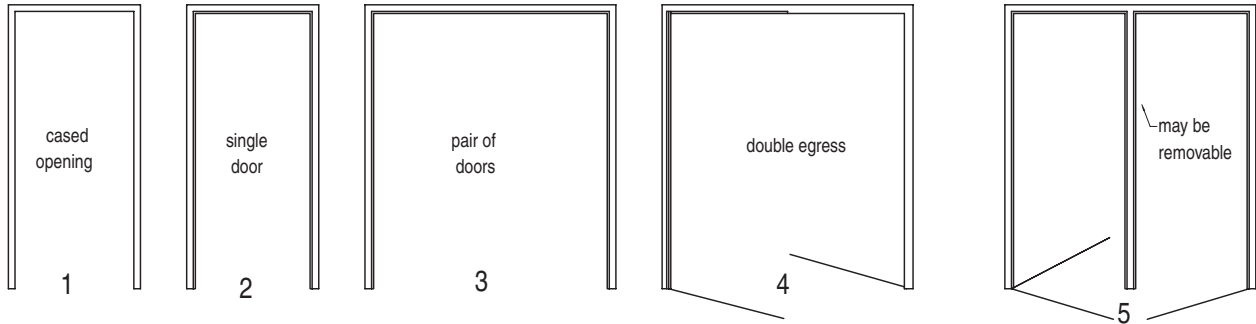
Copyright © 2008

**National Association of Architectural Metal Manufacturers**

All Rights Reserved

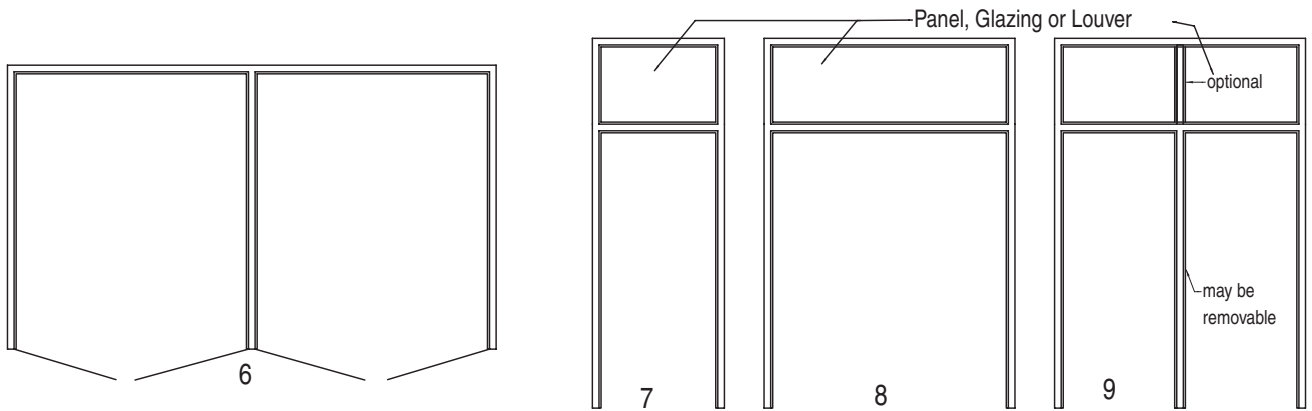
# HOLLOW METAL FRAMES

The primary function of the door frame is to provide support for the door and the components required for proper operation of the opening. Hollow metal frames serve other aesthetic or functional purposes, such as trimming a wall opening having no door, or enclosing glazed areas that provide through-wall visibility or admitting light and/or air. Hollow metal frames, which are strong, sturdy and durable, serve all such functions economically. Custom hollow metal frames are available in a broad array of configurations. Illustrated below are some of the more common and representative types, and on the following pages are shown the typical details of frame construction and assembly.



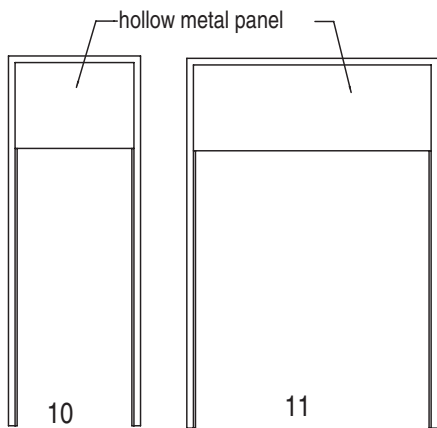
THREE-SIDED FRAMES

MULLION FRAME

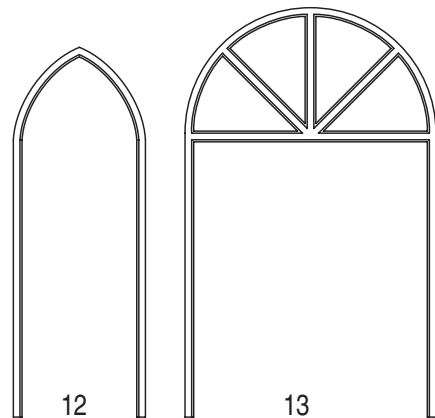


MULTI-OPENING FRAMES

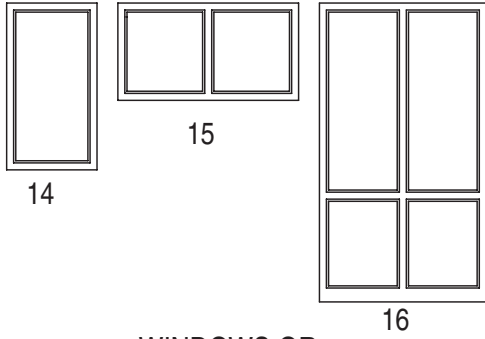
TRANSOM FRAMES WITH TRANSOM BAR



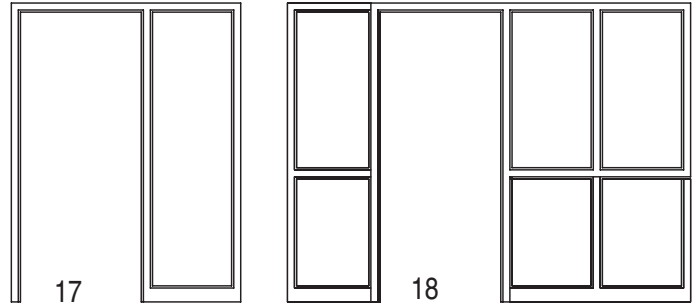
WITHOUT TRANSOM BAR



SPECIAL FRAMES

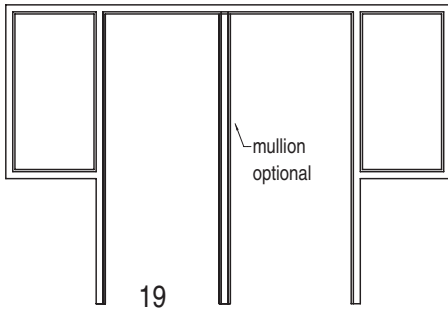


WINDOWS OR  
BORROWED LIGHTS

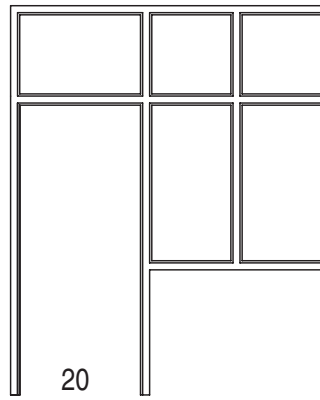


SIDELIGHT FRAMES

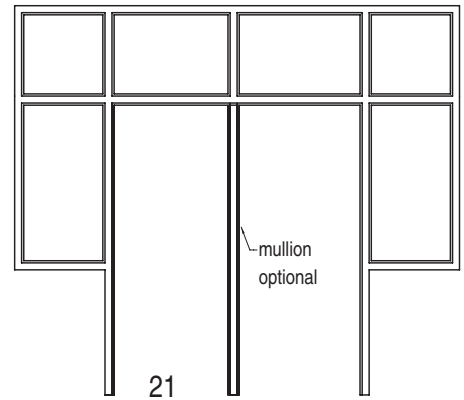
Panels may be used in lieu of glazing at sidelight frames



SIDELIGHT FRAMES

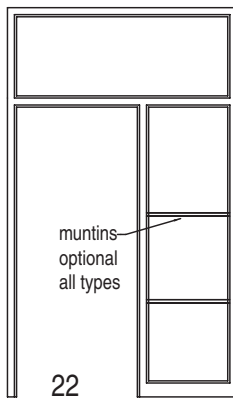


20

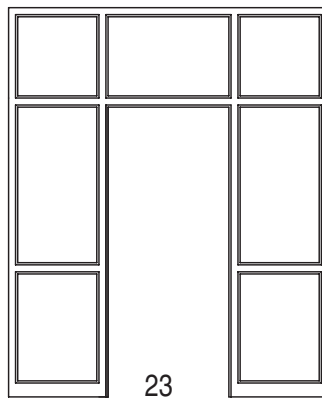


21

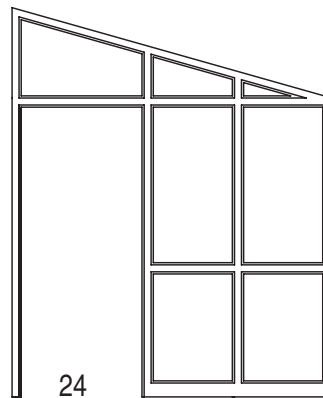
SIDELIGHT FRAMES WITH TRANSOMS



22

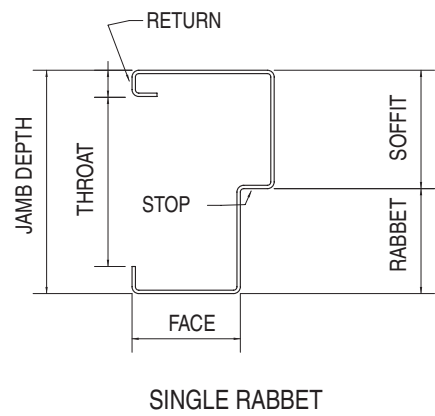
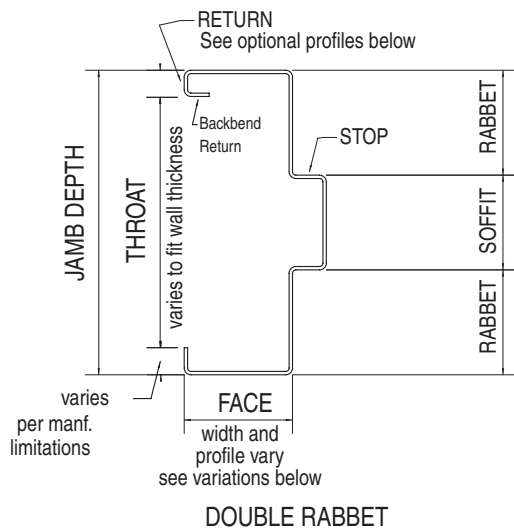


23

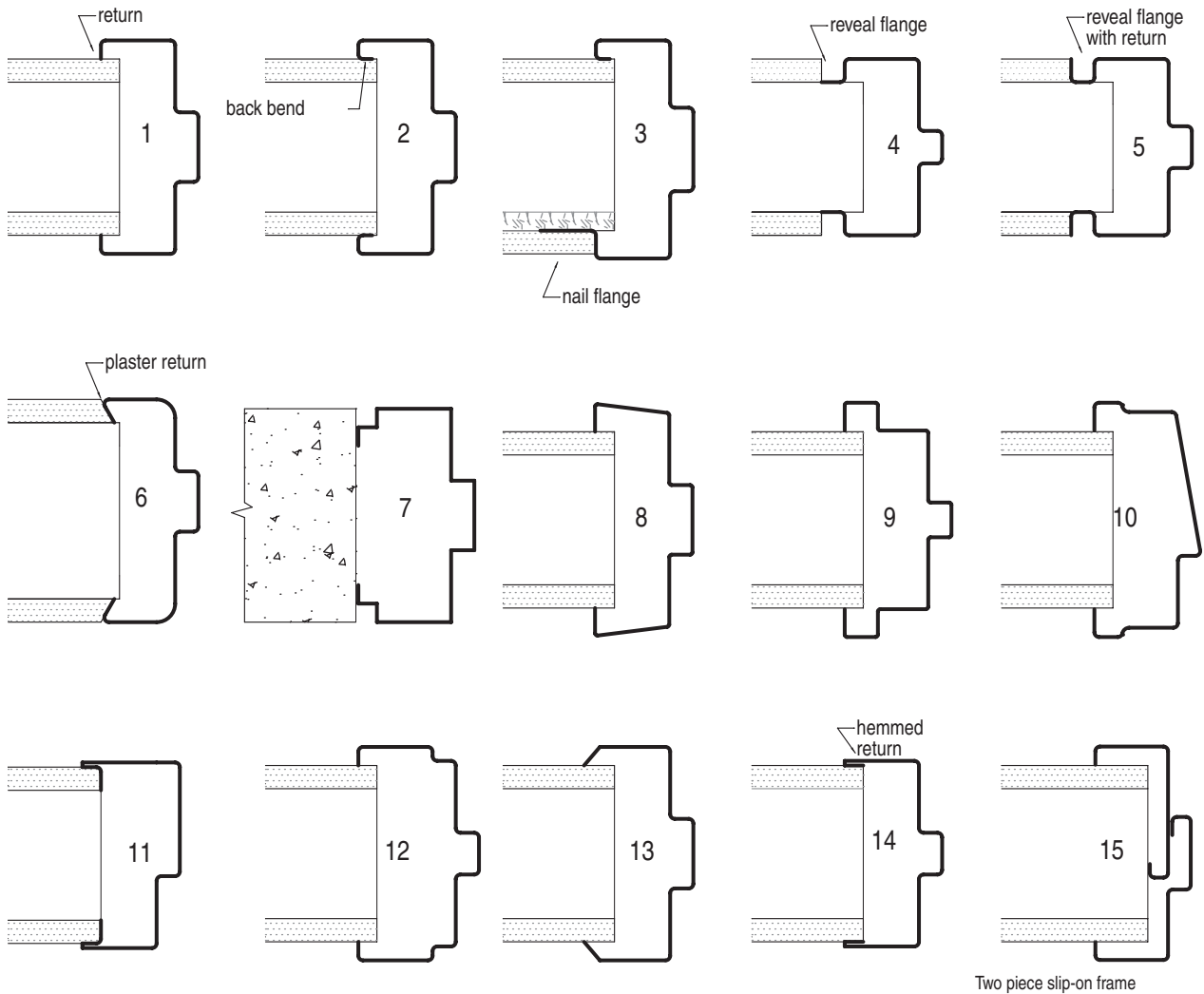


24

SIDELIGHT FRAMES WITH TRANSOMS

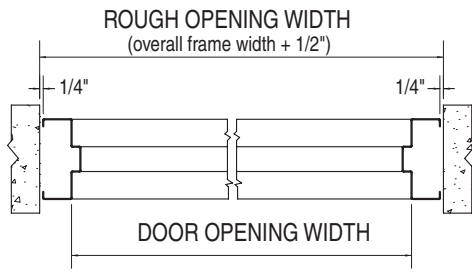


### FRAME PROFILE NOMENCLATURE

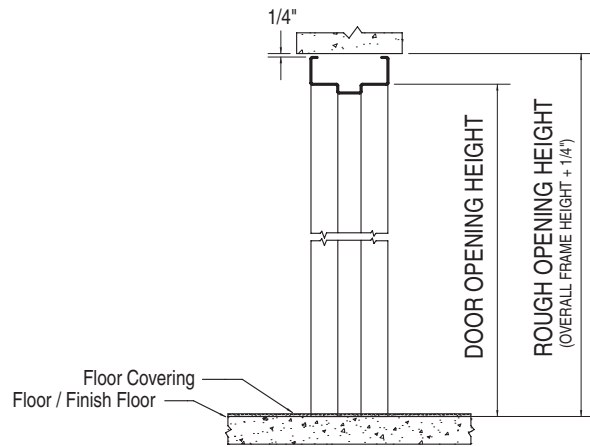


Any face profile may be combined with any backbend profile.

### REPRESENTATIVE FRAME PROFILES OTHER DESIGNS AVAILABLE

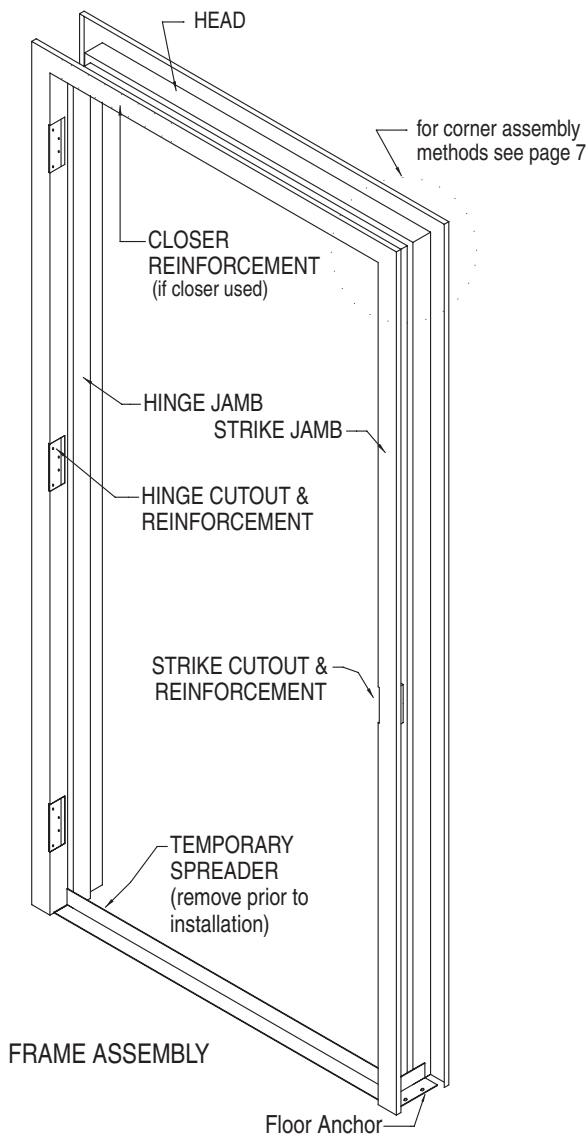


**HORIZONTAL  
FRAME DIMENSIONS**

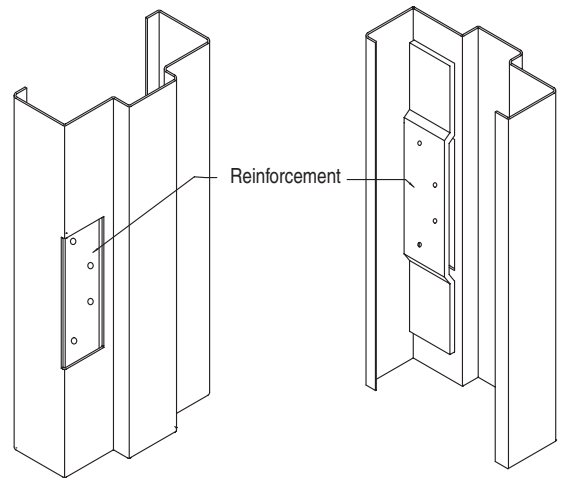


**VERTICAL FRAME DIMENSIONS**

For information on undercuts see  
HMMA-810 TN01-03 "Defining Undercuts"



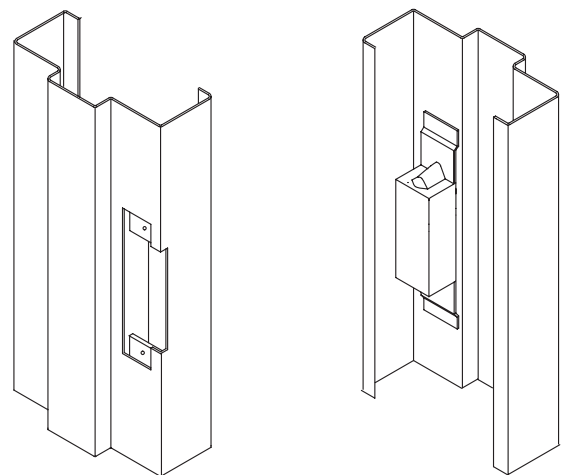
**FRAME ASSEMBLY**



**FACE VIEW**

**BACKSIDE VIEW**

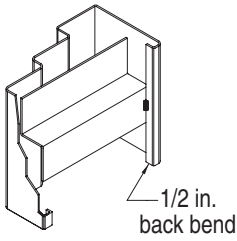
**HINGE PREPARATION**



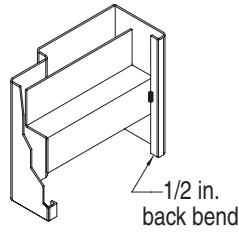
**FACE VIEW**

**BACKSIDE VIEW**

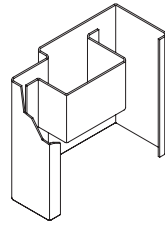
**STRIKE PREPARATION**



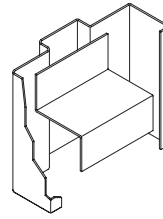
DOUBLE EGRESS  
STEEL STUD



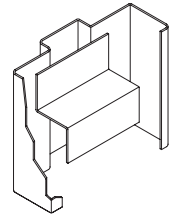
SINGLE RABBET  
STEEL STUD



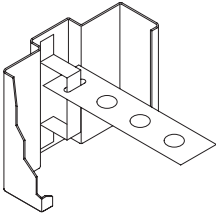
SINGLE RABBET  
STEEL STUD



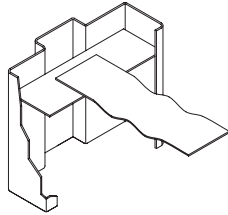
STEEL STUD  
FLUSH WITH RETURN



STEEL STUD  
INSET 1/2 IN. THROAT

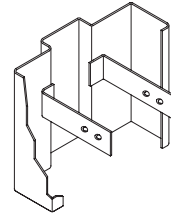


STRAP & STIRRUP  
(MASONRY)

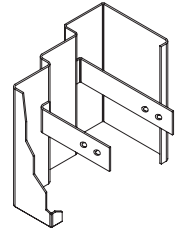


T-STRAP  
(MASONRY)

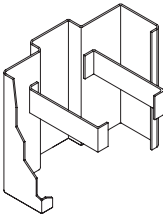
For information about  
the choice of anchor type  
see HMMA 840, "Installation  
and Storage of Hollow  
Metal Doors and Frames".



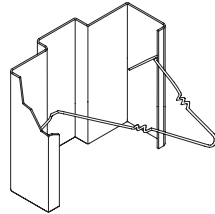
WOOD STUD  
TWO PIECE



DOUBLE EGRESS  
WOOD STUD  
TWO PIECE



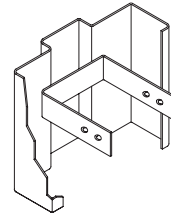
POUR IN PLACE  
(CEMENT)



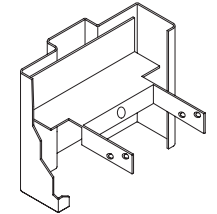
WIRE  
(MASONRY)

COMMON TYPES  
OF JAMB ANCHORS.

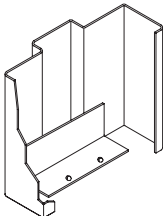
OTHER TYPES ARE  
AVAILABLE.



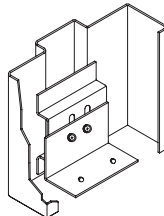
WOOD STUD  
ONE PIECE



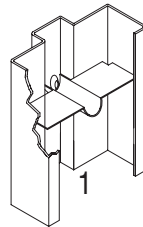
COMBINATION ANCHOR  
(MAY BE USED WITH WOOD  
OR STEEL STUD)



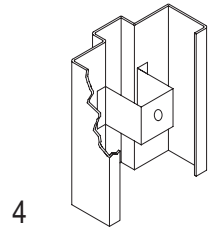
FIXED  
FLOOR ANCHOR



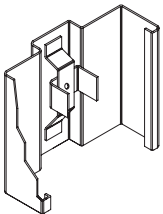
ADJUSTABLE  
FLOOR ANCHOR



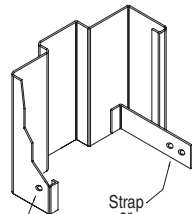
1



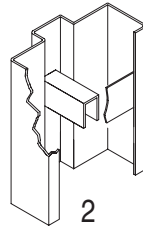
4



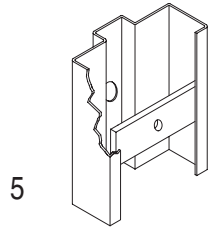
COMPRESSION ANCHOR  
FOR SLIP-ON DRYWALL FRAMES



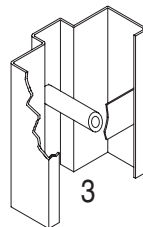
FLOOR ANCHOR  
FOR SLIP-ON DRYWALL FRAMES



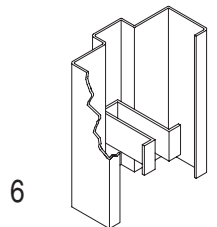
2



5

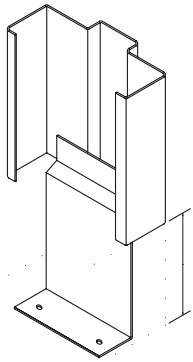


3



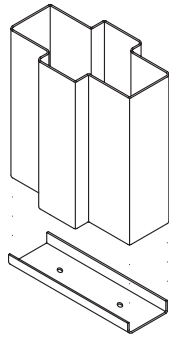
6

EXISTING WALL ANCHORS



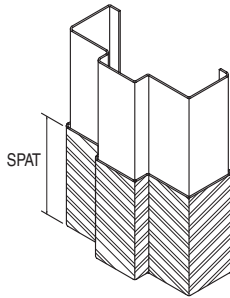
**FLOOR STILT**

Terrazzo  
or other  
base mtl.

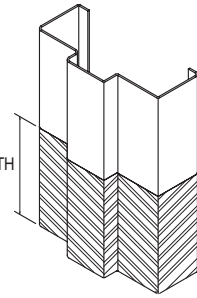


**FIXED MULLION ANCHOR**

Design may vary by manufacturer



Stainless steel  
wrap-around covering

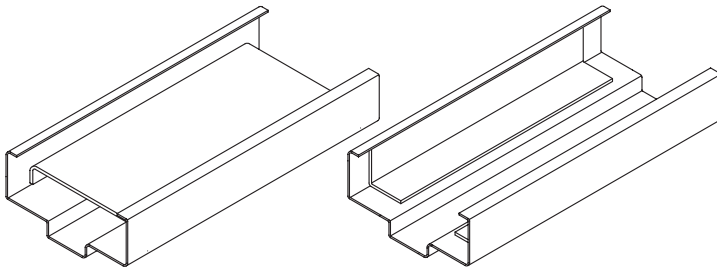


PLINTH

May be used with  
either cutoff or  
full length stops

Stainless steel same  
thickness as frame and  
flush with all jamb surfaces

**SPATS**

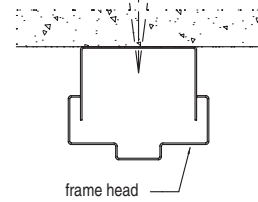


**CHANNEL**

**ANGLE**

Used on grouted masonry door openings over 48" to prevent deflection,  
see Appendix A, HMMMA-820 TN01-03, Grouting Hollow Metal Frames  
NOT TO BE USED AS LINTEL OR LOAD BEARING MEMBER

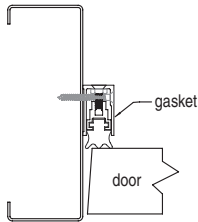
**HEAD REINFORCEMENTS**



frame head

**HEAD ADAPTER**

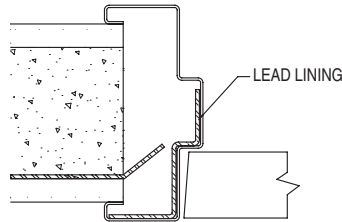
For frames extending  
from slab to slab



gasket

door

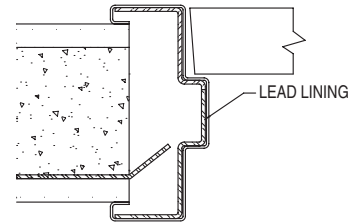
**SOUND CONTROL FRAME**



LEAD LINING

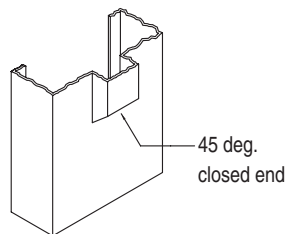
SOURCE OF RADIATION

**LEAD-LINED FRAME**

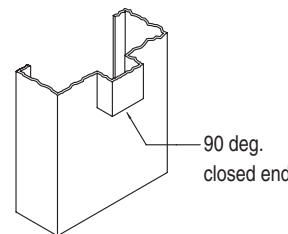


LEAD LINING

SOURCE OF RADIATION



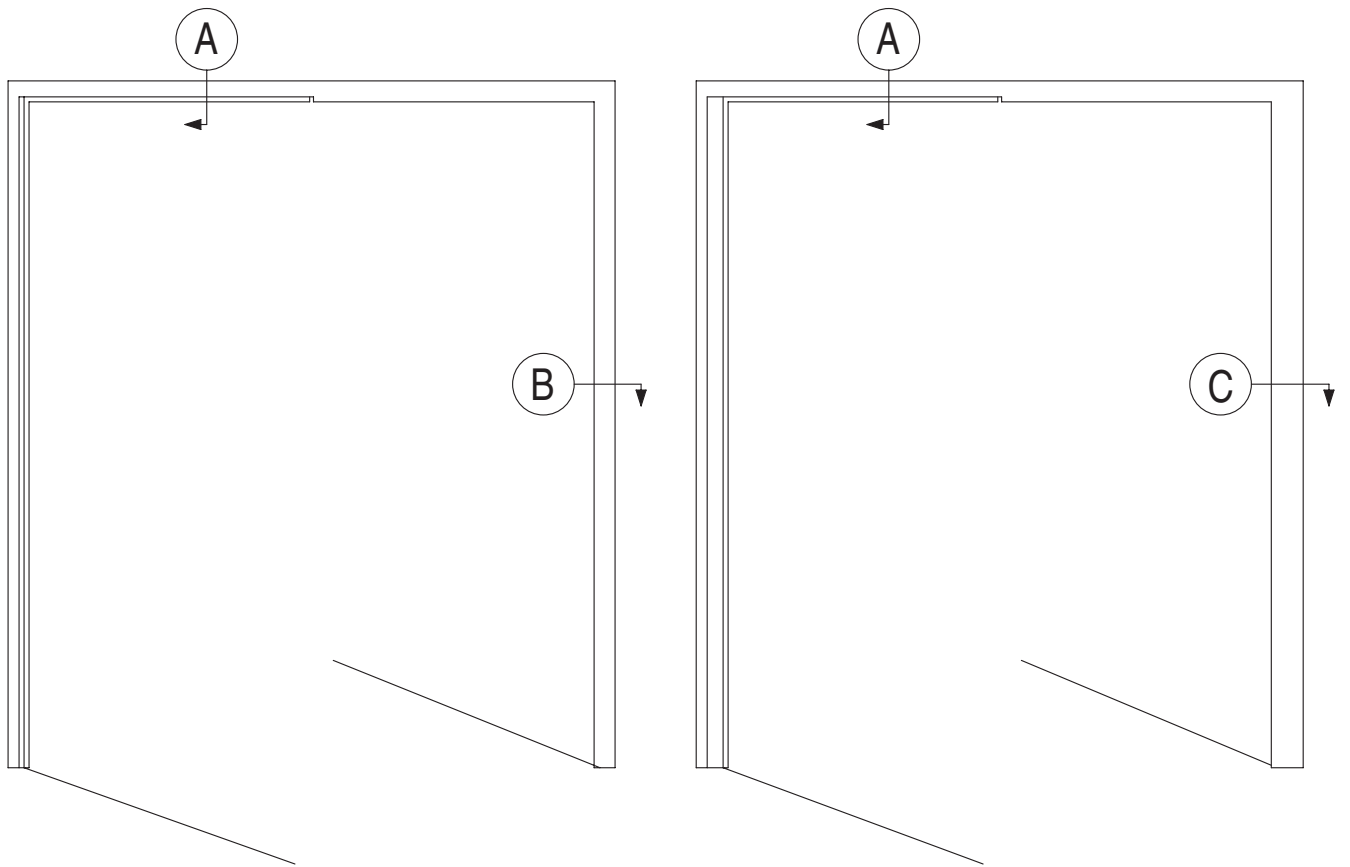
45 deg.  
closed end



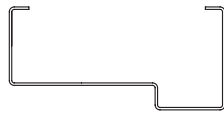
90 deg.  
closed end

**CUTOFF (SANITARY) STOPS**  
6" maximum height at fire rated openings





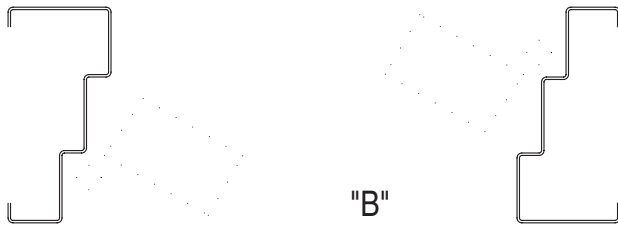
KEY ELEVATIONS



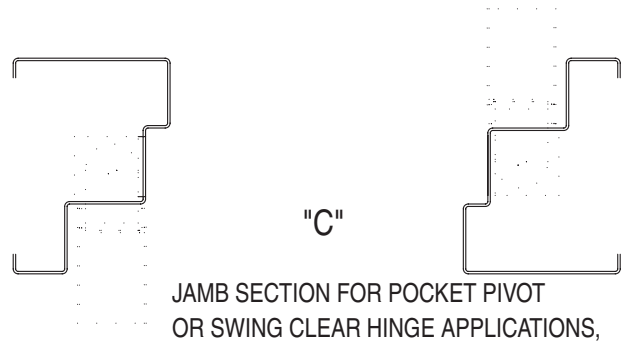
TYPICAL  
HEAD SECTIONS  
"A"



ALTERNATIVE  
HEAD SECTION

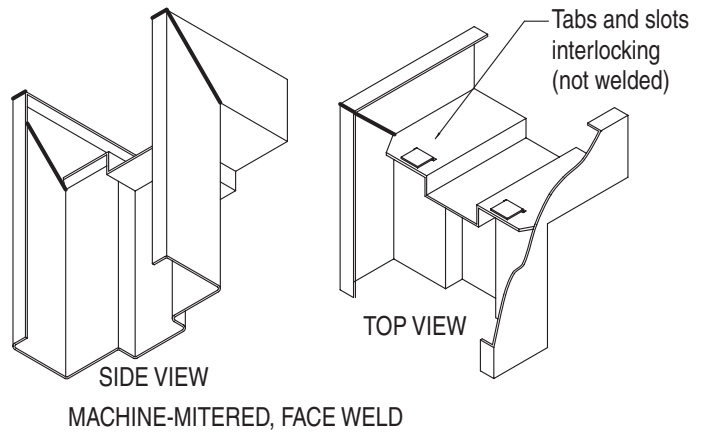
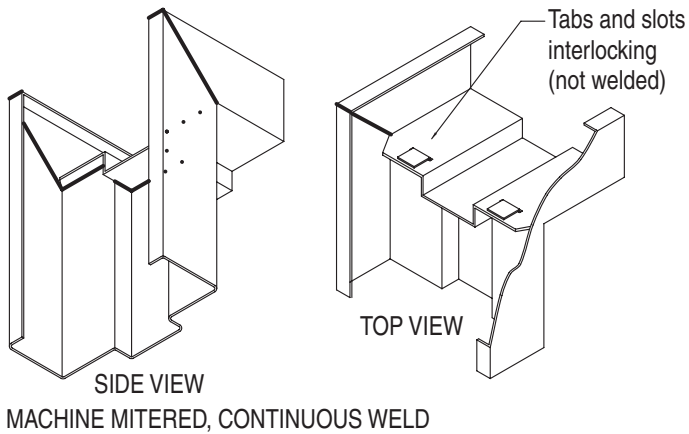


"B"  
TYPICAL JAMB SECTIONS

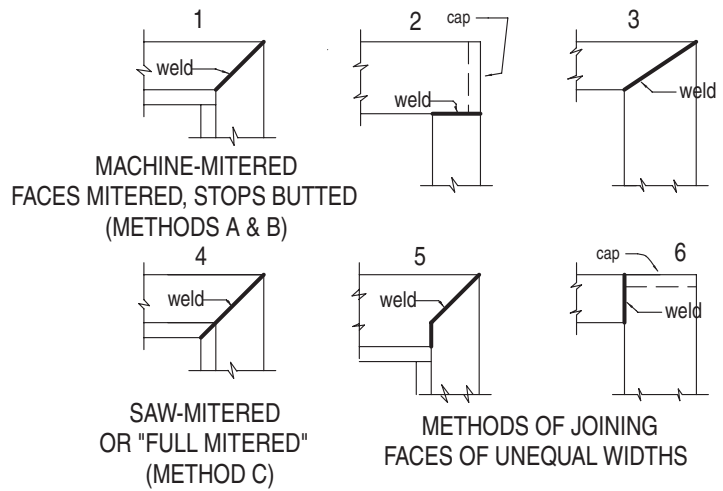
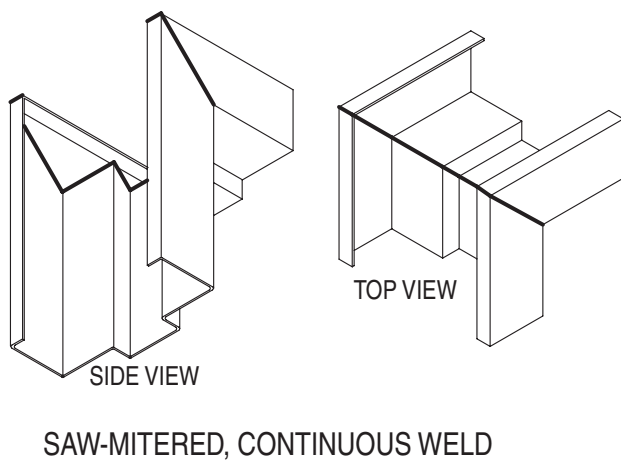


"C"  
JAMB SECTION FOR POCKET PIVOT  
OR SWING CLEAR HINGE APPLICATIONS,

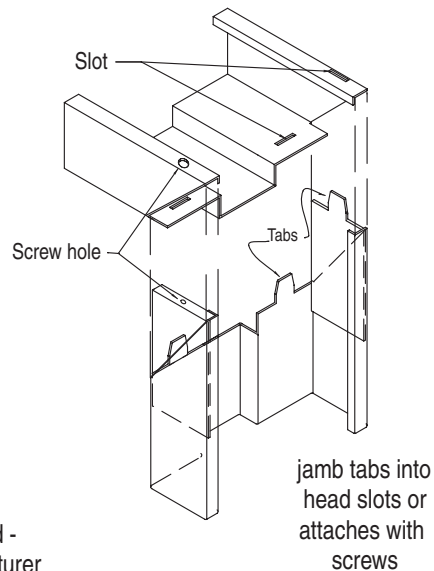
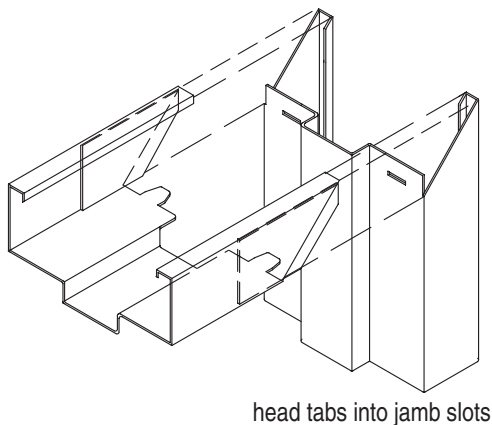
DETAILS FOR DOUBLE EGRESS FRAME



All exposed welds ground and finished smooth



WELDED FRAME CORNER DETAILS

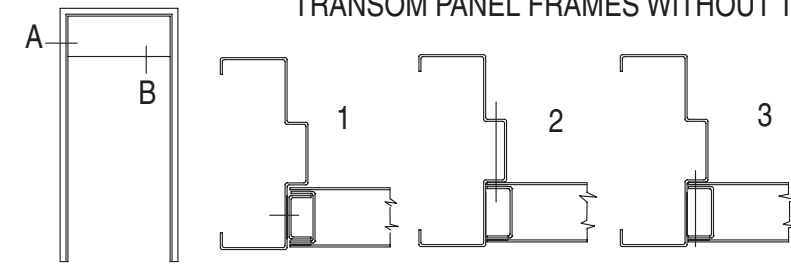


REPRESENTATIVE  
CORNER DETAILS

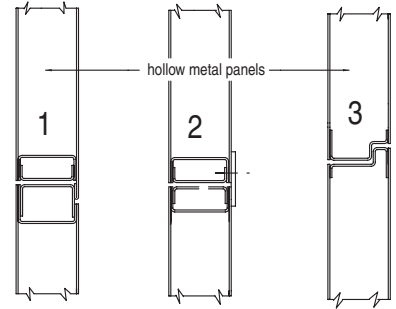
Other methods also used -  
systems vary with manufacturer

KNOCKDOWN FRAME CORNER DETAILS

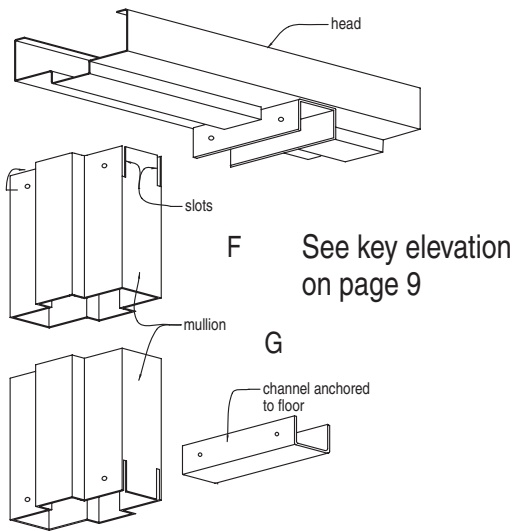
TRANSOM PANEL FRAMES WITHOUT TRANSOM BARS



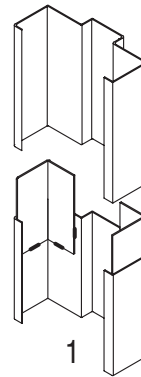
KEY ELEVATION  
ALTERNATIVES - SECTION A - HOLLOW METAL PANELS



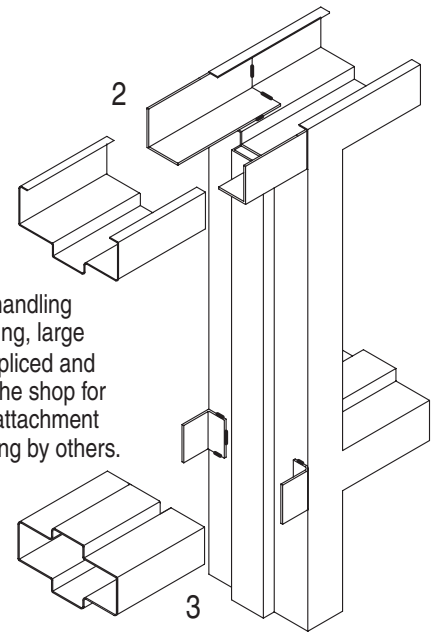
HOLLOW METAL DOORS  
ALTERNATIVES - SECTION B



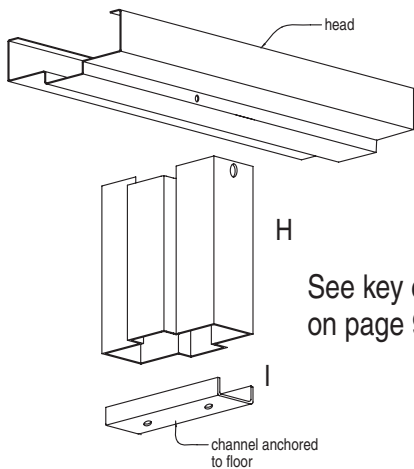
See key elevation  
on page 9



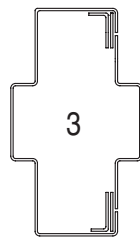
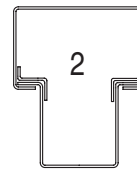
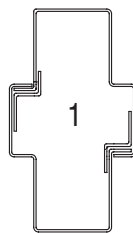
To facilitate handling  
and/or shipping, large  
frames are spliced and  
prepared in the shop for  
mechanical attachment  
or field welding by others.



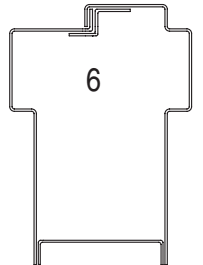
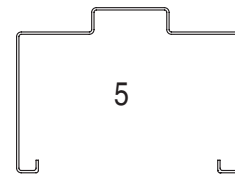
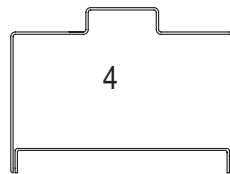
FIELD SPLICES FOR LARGE MULTI-OPENING FRAMES



See key elevation  
on page 9



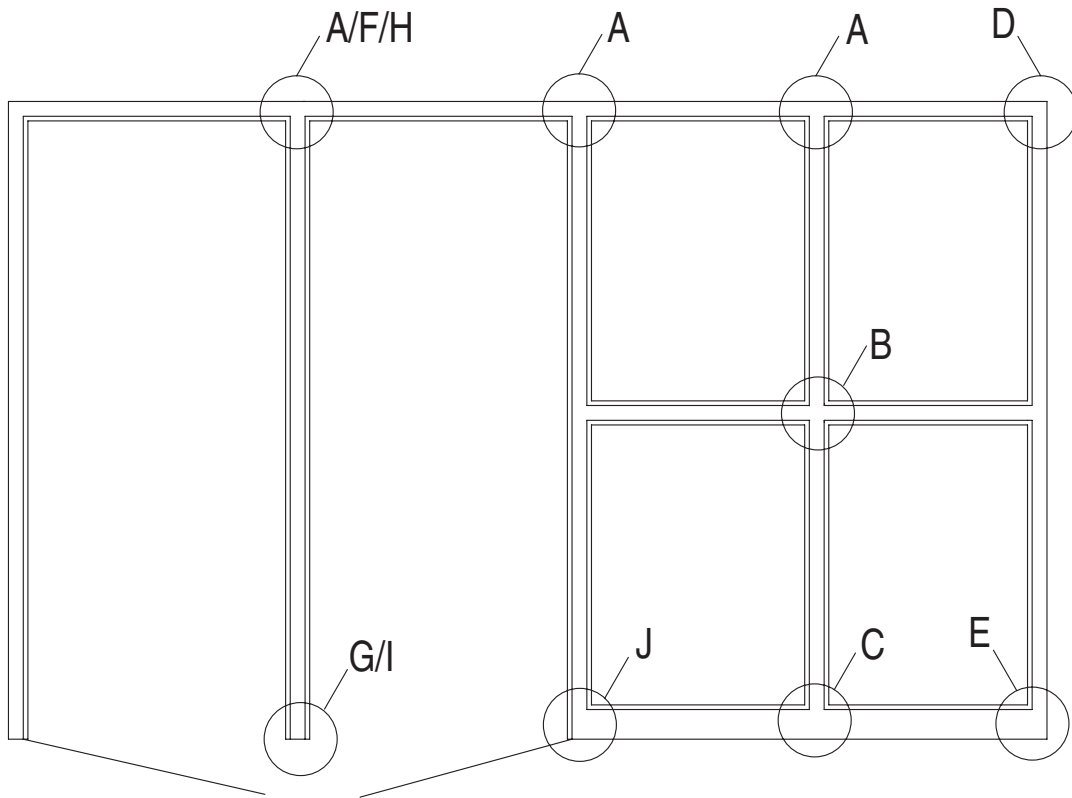
MULLION SECTIONS



BASE (OR SILL) SECTIONS

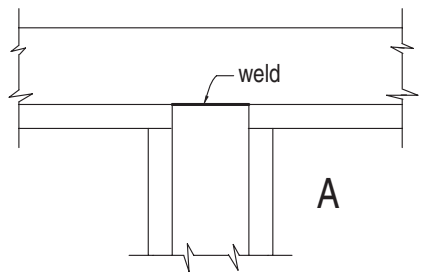
ANCHORING AND ATTACHING  
REMOVABLE MULLIONS VARIES  
PER MANUFACTURER

TYPICAL DETAILS FOR FRAME PRODUCT

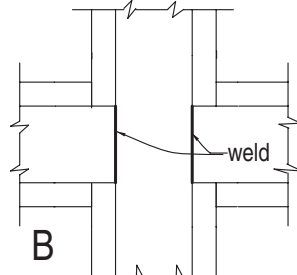


KEY ELEVATION

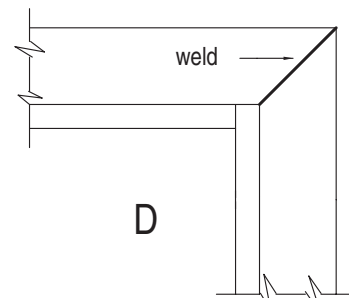
Note: See page 9 for details F, G and H, I



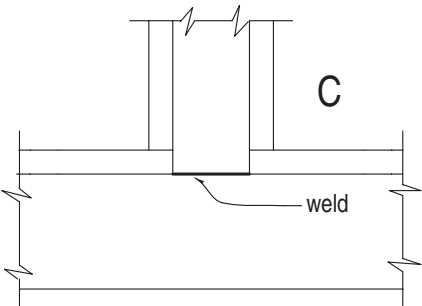
MULLION TO HEAD



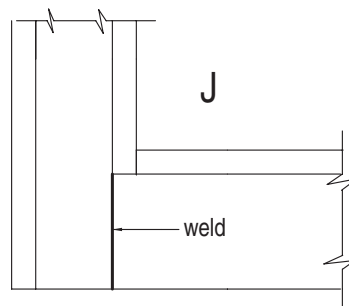
MULLION INTERSECTION



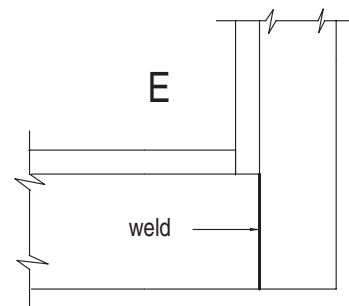
HEAD TO JAMB



MULLION TO SILL



SILL TO VERT. MULLION

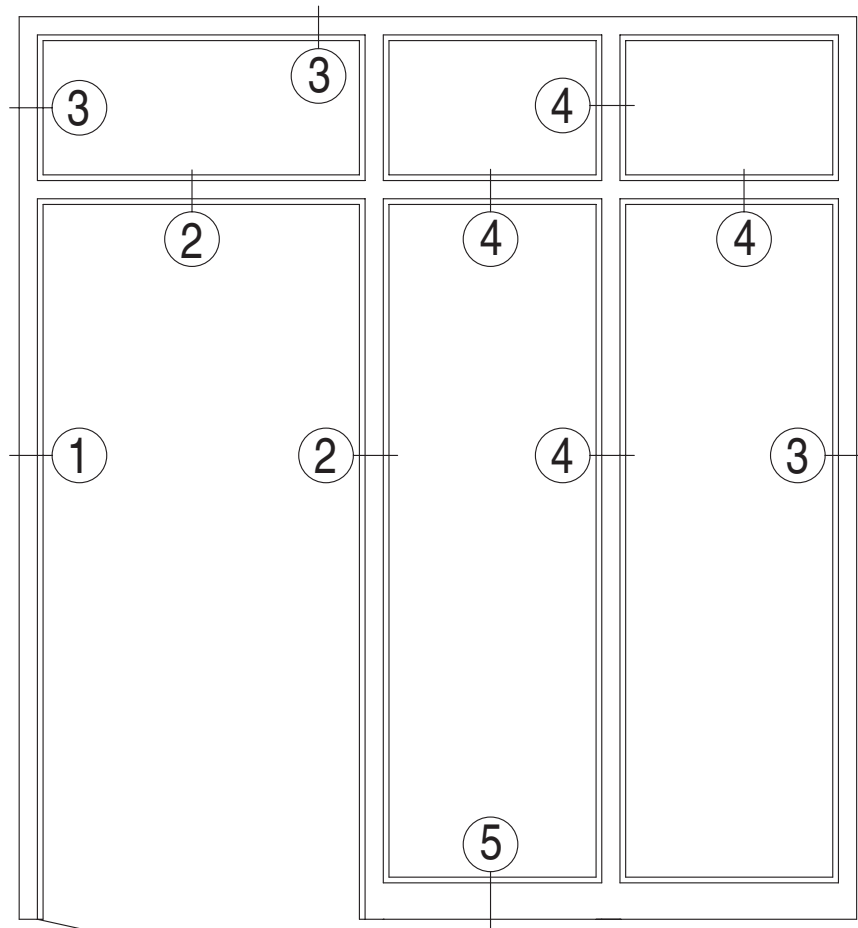


SILL TO JAMB

**BUTTED AND FACE-WELDED ASSEMBLY JOINTS**

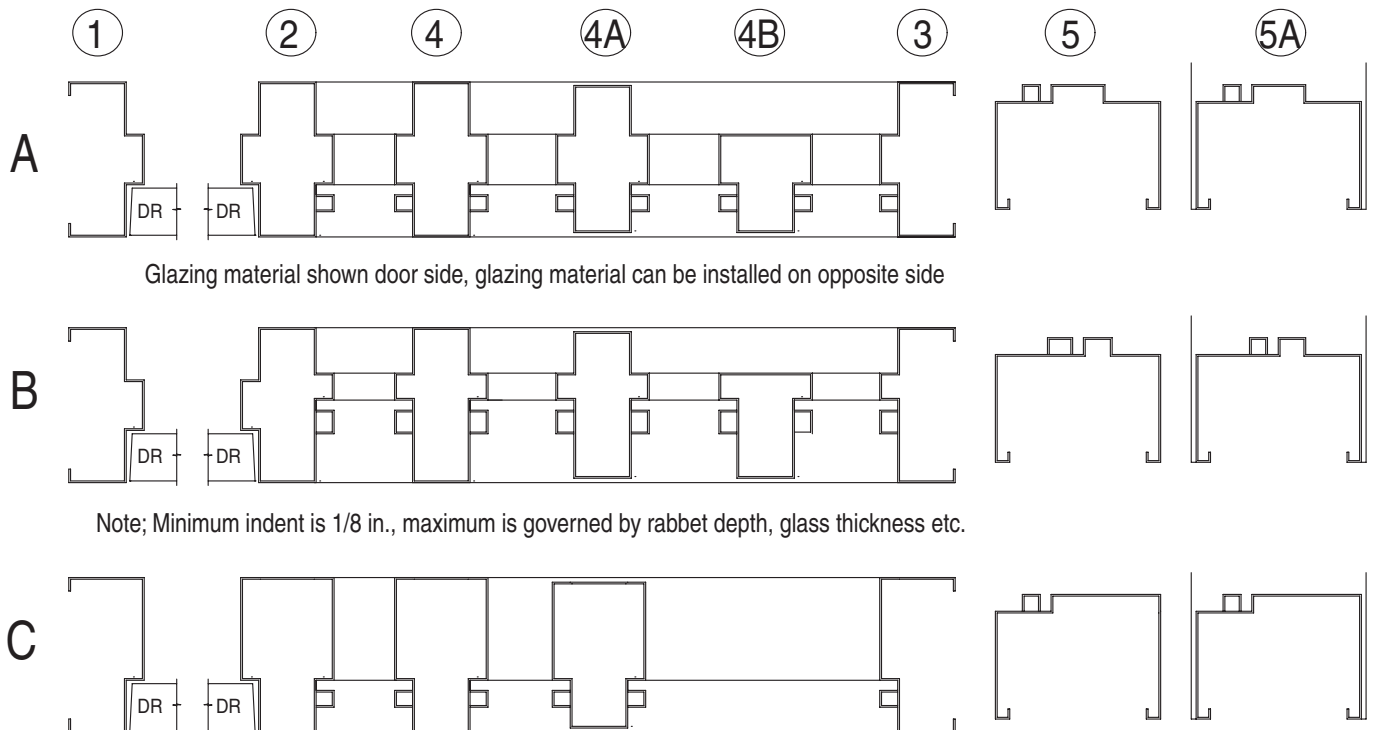
All welds ground and finished smooth

For more information on welding see Appendix B, HMMA-820 TN02, Continuously Welded Frames

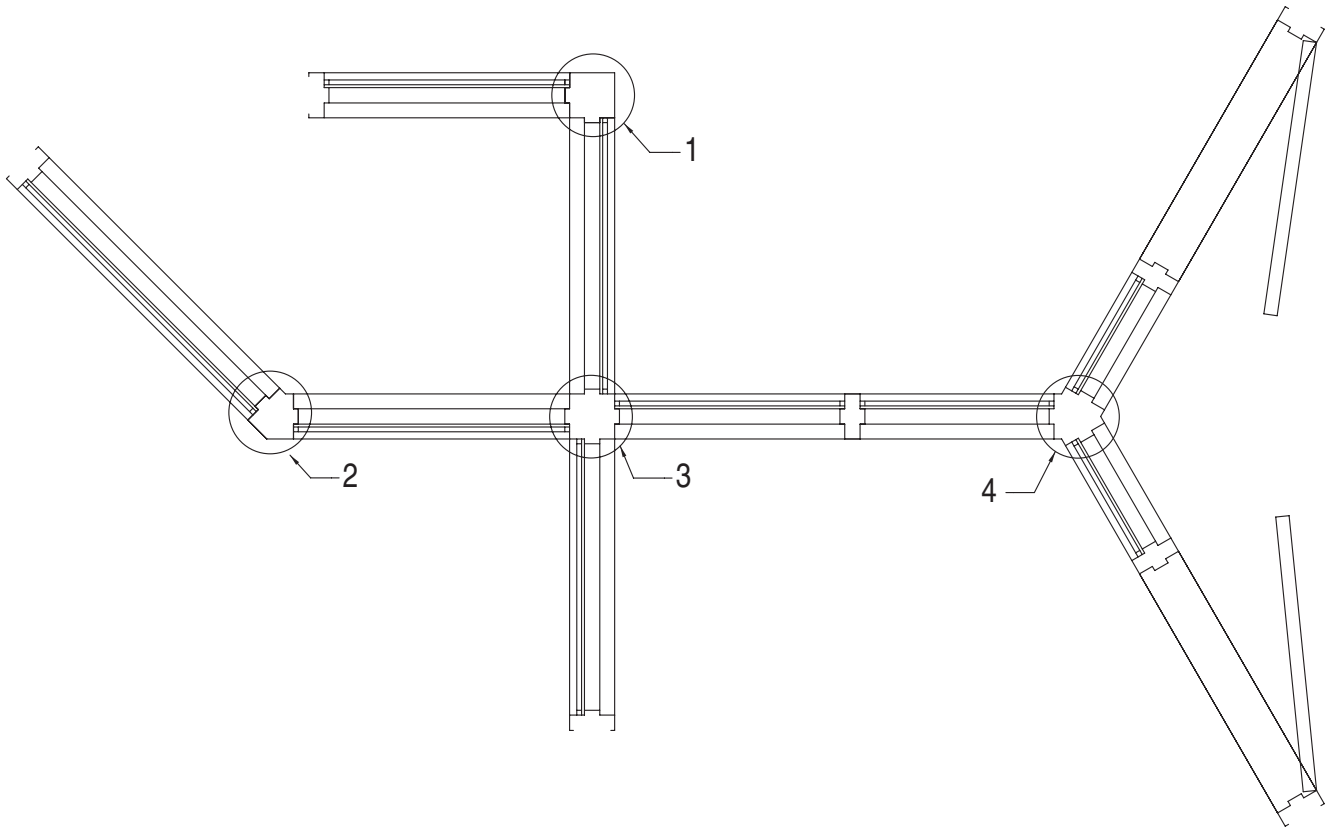


SIDELIGHT FRAME ELEVATION WITH REPRESENTATIVE DETAILS

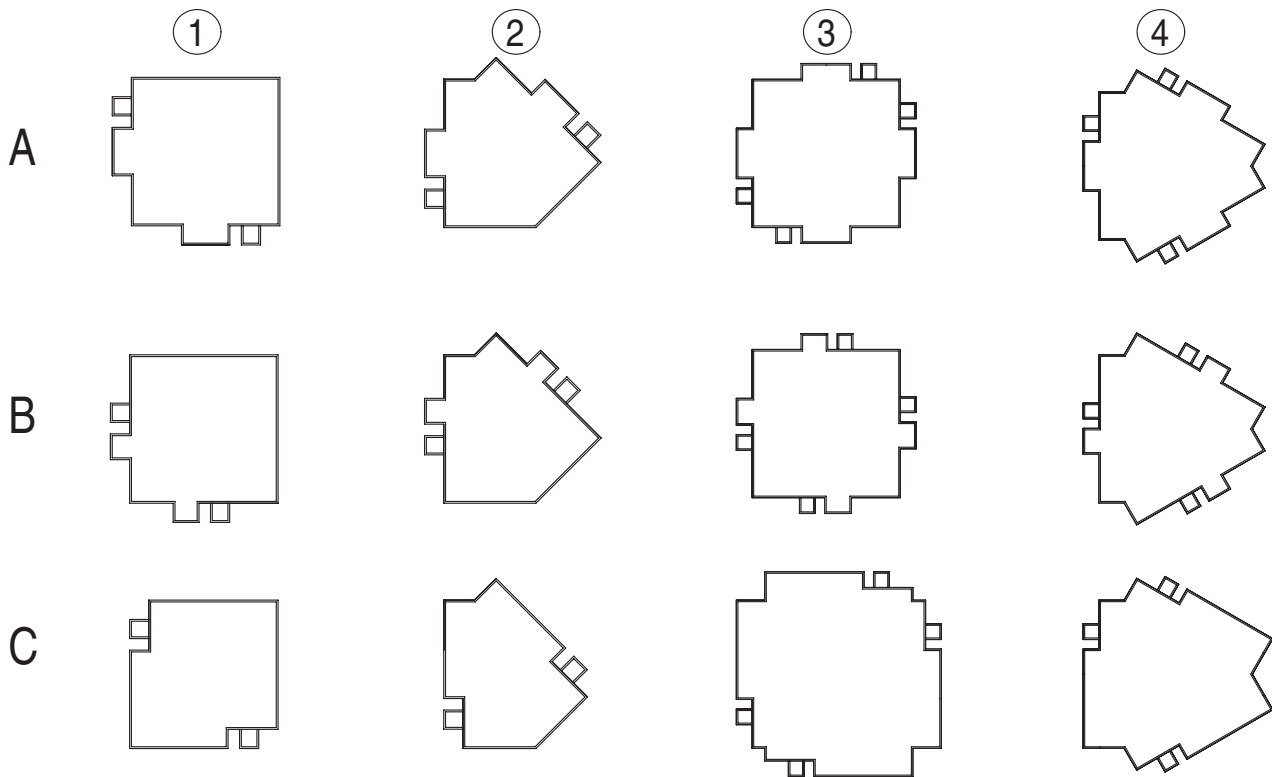
OPTIONAL INDENTED MULLION AND SILL SECTIONS @ 4A, 4B AND 5A



SEGMENTED SIDELIGHT / BORROWED LIGHT FRAME  
WITH CORNER MULLION POSTS



CORNER MULLION SECTIONS



## Grouting Hollow Metal Frames

Grout, when used in accordance with industry guidelines, can improve frame durability, sound deadening, and, depending on wall construction, increase frame anchorage strength. Grouting of the frame does not increase door durability, nor is it required for fire-rated frames. For most commercial applications, grouting of mullions and other closed sections is not recommended.

For applications covered by ANSI/NAAMM HMMA 862, “Guide Specifications for Commercial Security Hollow Metal Doors and Frames,” and ANSI/NAAMM HMMA 863, “Guide Specifications for Detention Security Hollow Metal Doors and Frames,” the standards require that “frame jambs shall be fully grouted to provide added security protection against battering, wedging, spreading, and other means of forcing open the door”.

Grout is a water-based product. If not used properly, it can destroy the opening in a very short time. Grout can be either “mortar”, which is a masonry mixture of lime, cement, sand, and water, or “plaster”, which is a gypsum-based product.

Plaster grout dries by exposure to air. When a frame member is filled solid with plaster grout, only those areas exposed to air will dry and harden, while the center remains wet (uncured). The water remaining in the plaster grout can rust the frame from the inside. Plaster grout should not be used.

Mortar grout cures by chemical reaction and hardens throughout. Use mortar grout.

Frames are not designed to act as forms for grout. Grout must have a maximum 4 in. slump and be hand troweled in place. Bracing of the frame may be necessary prior to grouting to prevent sagging of the header or bowing of the jamb due to weight or pressure of the grout. Grout should not be installed after gypsum wallboard is installed, as the liquid within the grout will deteriorate the wallboard.

When dictated by temperatures, anti-freezing agents for mortar may be recommended by specifications. These agents can adversely affect metal, and all surfaces in contact with the grout must be coated with a corrosion resistant material.

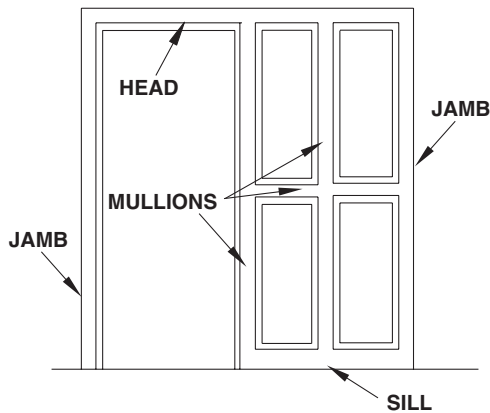
It is recommended that the contractor be responsible for the grouting and for any required barrier coating. It is also his responsibility to use care in the application of the grout.

## Continuously Welded Frames

Also called Full, Fully and or Full Profile Welded.

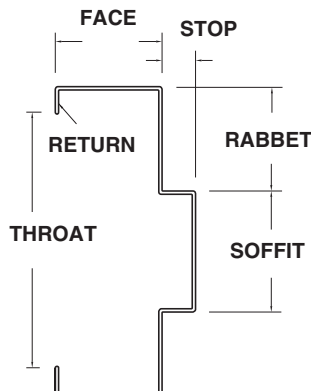
Established definitions and nomenclature:

1. FRAME MEMBER – A part of a frame such as a head, jamb, mullion or sill, also called frame profile, see Figure #1.



**Figure #1**

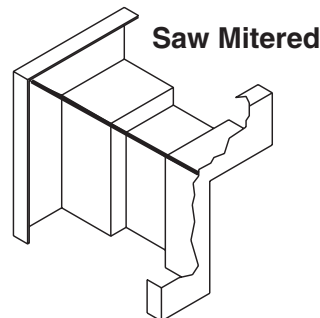
2. FRAME ELEMENTS – Specific parts of a frame member such as soffit, stop, rabbet, face and return. See Figure #2. A double rabbeted frame shown for illustration purposes only; alternate designs use the same nomenclature.



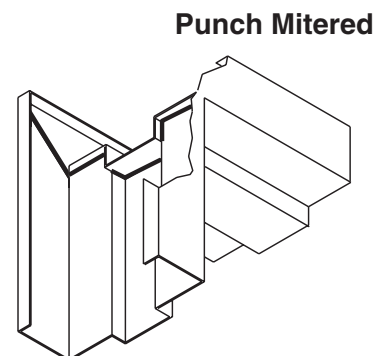
**Figure #2**

3. PERIMETER JOINT – The intersection of two or more frame members or elements that are accessible through the throat or from the unexposed side of the frame member. As perimeter applies, this is the outside boundary of the frame.

Perimeter joints of a continuously welded frame shall have all elements of the frame member continuously welded; soffits, stops, rabbets, faces and returns. Faces and returns may be welded either internally or externally. Soffits, stops, and rabbets shall be welded internally. Figures #3A – #3D illustrates typical perimeter joints; Figure #3A illustrates a saw and punched mitered corner joint.



**Saw Mitered**



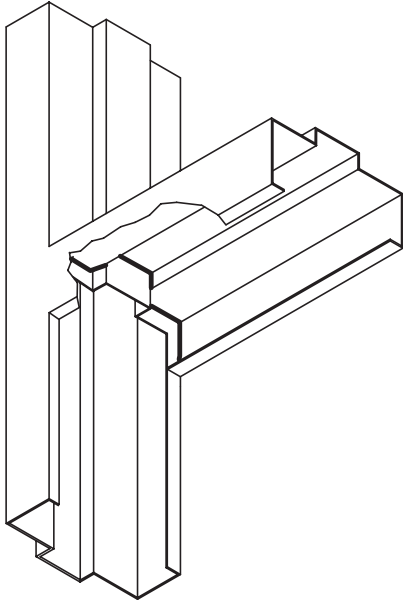
**Punch Mitered**

**Figure #3A**



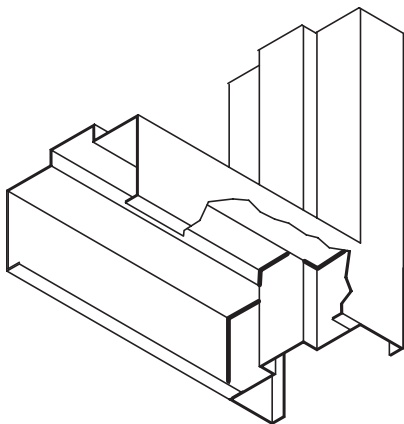
With many frame configurations the frame perimeter may not be square or rectangular, permitting a mitered corner. Figures #3B – #3D illustrate butted flush perimeter joints.

Figure #3B illustrates a typical sidelight frame where the sidelight does not extend to the floor.



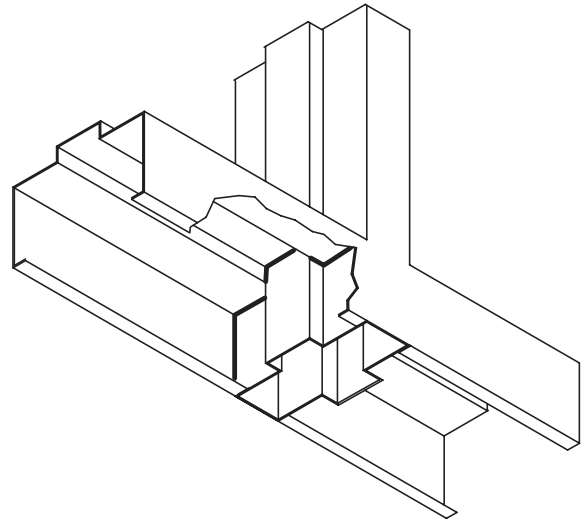
**Figure #3B**

Figure #3C illustrates a sidelight frame where the sidelight extends to the floor.



**Figure #3C**

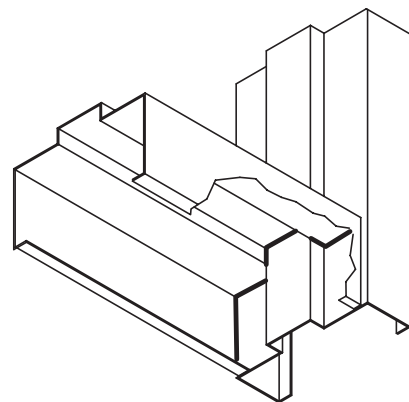
Figure #3D illustrates a sidelight or smokescreen, where the vertical mullion is designed to extend to the floor.



**Figure #3D**

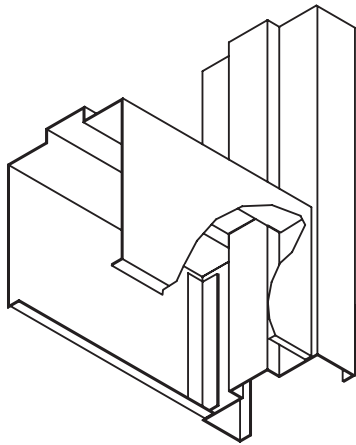
Occasionally the sill, as with other frame members, is intended to be indented. As this is a perimeter joint, all elements of the frame members should be continuously welded, but due to design and/or construction requirements this is not feasible. Therefore, it is necessary to alter construction methods.

Figure #4A illustrates an indented sill that is continuously welded.



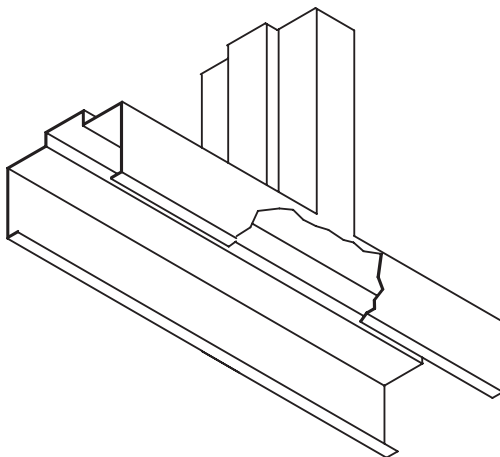
**Figure #4A**

Figure #4B, although drawn similar to Figure #4A, illustrates an indented sill that is reinforced with angles at the faces in lieu of continuously welding. These angles run the full height of the joint and are welded to both frame members. The rabbets, stops and soffit are continuously welded.



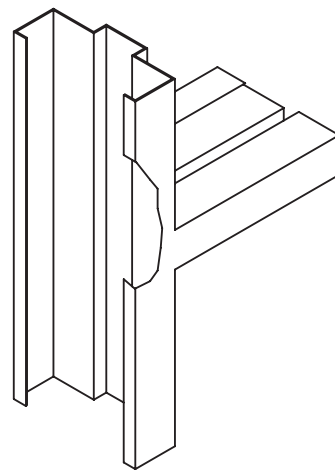
**Figure #4B**

Referring to Figure #3D, if this same horizontal frame member is not accessible through the throat or from the unexposed side of the frame member then this would be considered an internal joint, see Figure #5A.

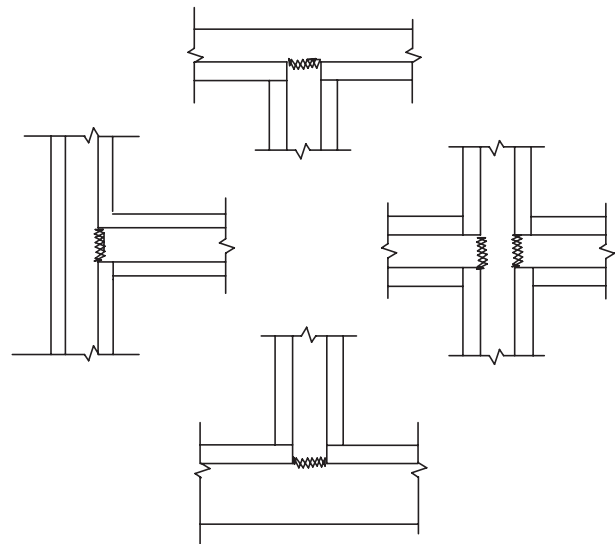


**Figure #5A**

Internal flush joints shall be face welded only. Joints at soffits, stops and rabbets are not welded and appear as a hairline seam. Figures #5A, #5B and #5C all illustrate internal joints. Note at Figures #5A & #5B that the internal frame member is not accessible from the inside throat of the perimeter frame member. This is the same situation whether it be a mullion and header, two mullions, or mullion and sill as shown in Figure #5C. At Figure #5C the etched line represents where the face joint would be welded. This, of course, would be finished smooth.

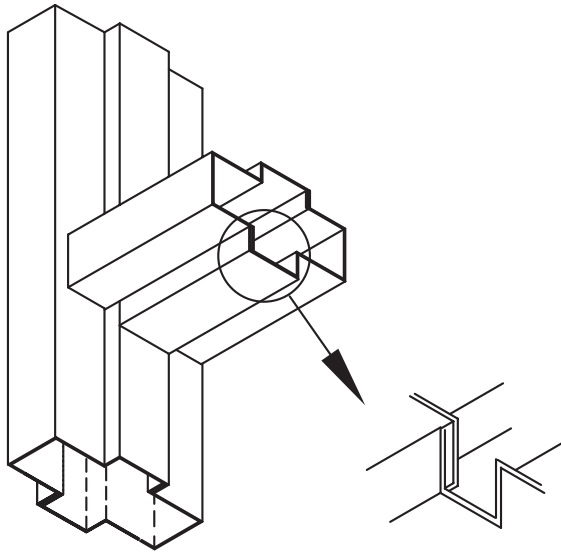


**Figure #5B**



**Figure #5C**

Indented joints at internal frame members shall be internally reinforced and welded. Joints at faces, soffits, stops and rabbets are not welded and appear as hair line seams. Mullions are constructed with an overlapping seam. This seam is internally connected and appears as a hairline seam. See Figure #6.



**Figure #6**

## **RECOMMENDED GUIDE SPECIFICATIONS FOR HMMA HOLLOW METAL DOORS AND FRAMES**

**HMMA 860 — Hollow Metal Door and Frames**

**ANSI/NAAMM**

**HMMA 861 — Commercial Hollow Metal Doors and Frames**

**ANSI/NAAMM**

**HMMA 862 — Commercial Security Hollow Metal Doors and Frames**

**ANSI/NAAMM**

**HMMA 863 — Detention Security Hollow Metal Doors and Frames**

**ANSI/NAAMM**

**HMMA 865 — Swinging Sound Control Hollow Metal Doors and Frames**

**ANSI/NAAMM**

**HMMA 866 — Stainless Steel Hollow Metal Doors and Frames**

**ANSI/NAAMM**

**HMMA 867 — Commercial Laminated Core Hollow Metal Doors and Frames**